

Slalom mixer - Concrete instruction

Mixer is located between channels outside stable

25.02.2021

Concrete must dry at least 8 days before installation of the plant is started.

1. Hole for $\varnothing 160$ mm outlet pipe
2. Secondary placement
3. Centre line water seal
4. Minimum 1,5 m slatted floor on both sides of the slalom mixer
5. Bottom edge of the siphon: Same depth as channel in stable
6. Minimum same level as slatted floor in stable

A-A (1 : 50)

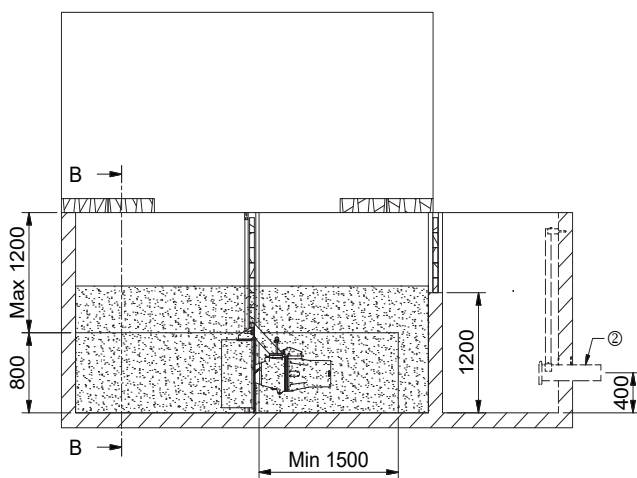

B-B (1 : 50)

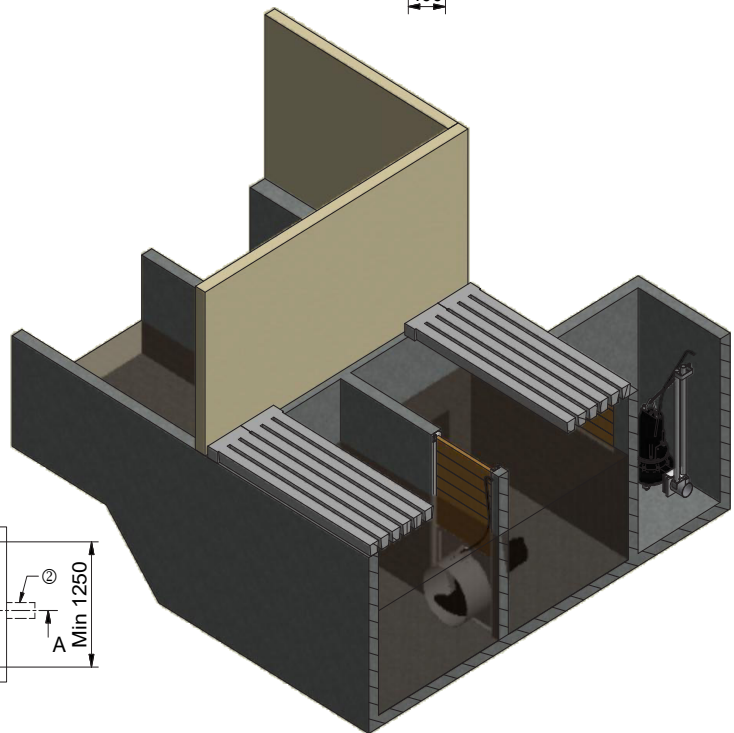
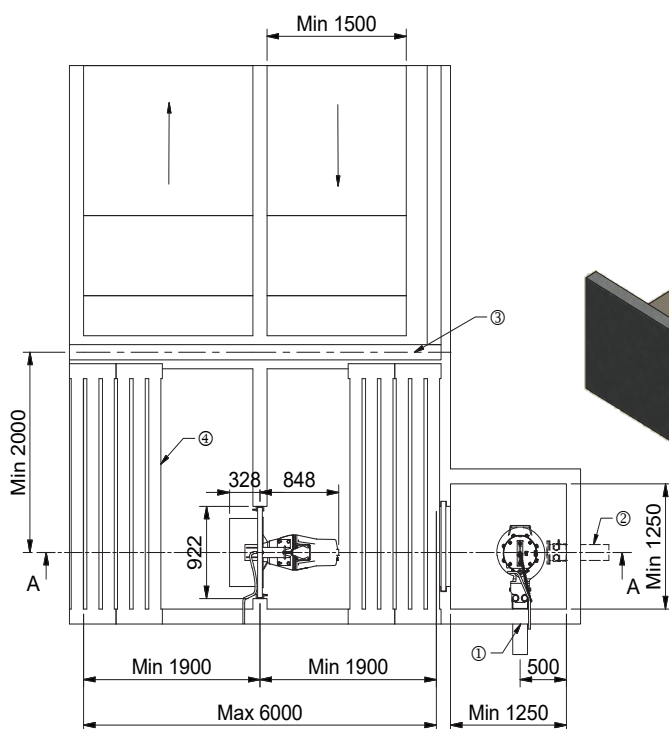
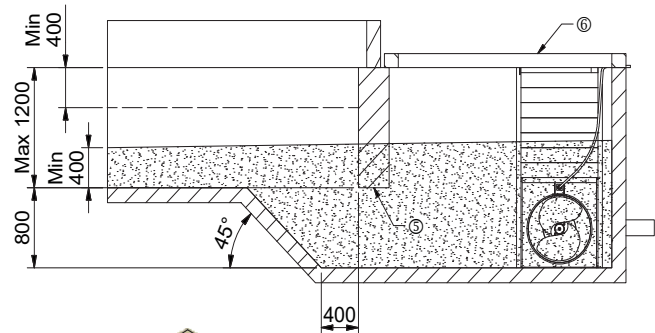

Slalom mixer - Concrete instruction

Alternative location

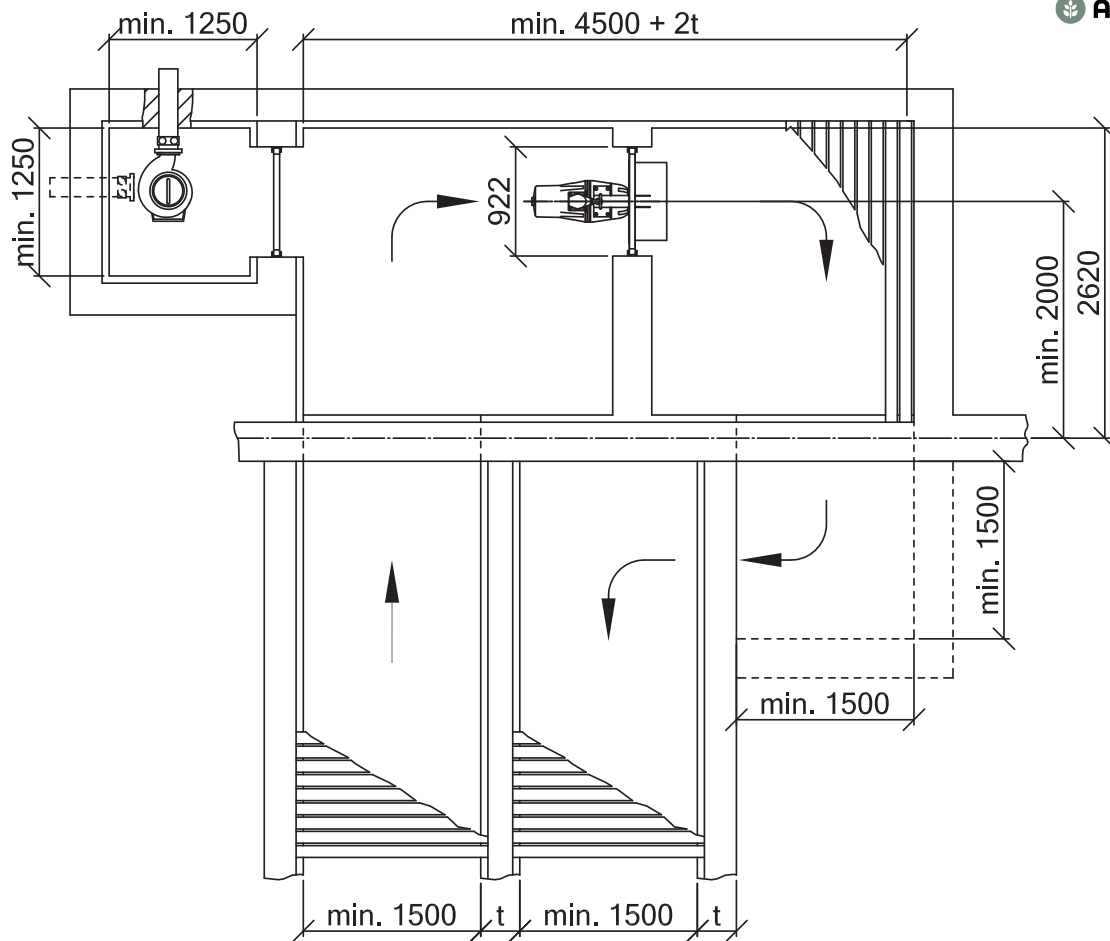

From water seal to slalom mixer

